

CROSS-OVER STRETCH FIT TABLE COVER

— Assembly Instructions —

CONTENTS SUPPLIED

EACH KIT INCLUDES :

(a.) Table Cover Graphic

4', 6' and 8' Graphic Available

(a.) Table Cover Graphic x2



STEP 1

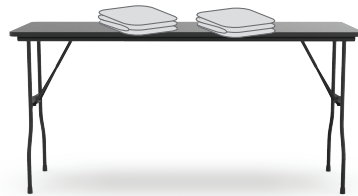

Place both Table Cover Graphics on the table top.

STEP 2

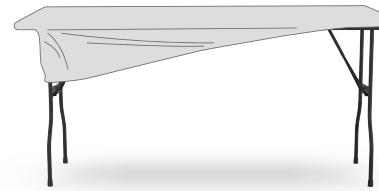

Cover the table top with the first graphic.

STEP 3

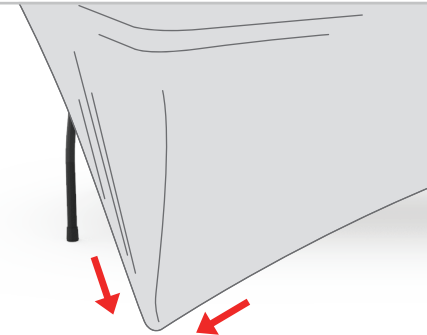

Stretch & secure the cover on the legs using the foot pockets.

STEP 4

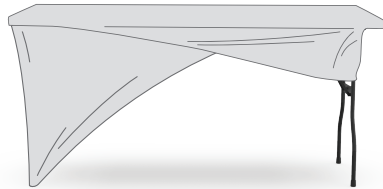

Place the second graphic over the first, then pull over the table top.

STEP 5

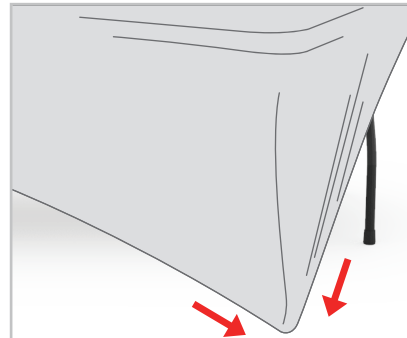

Stretch & secure the cover on the legs using the foot pockets.

FINISH

